

Clamping Levers with Eccentric Cam

with Internal Thread / with Threaded Stud,
Contact Plate Plastic

SPECIFICATION

Types

- Type **A**: Plastic contact plate with setting nut
- Type **B**: Plastic contact plate without setting nut

Lever

Zinc die casting

Powder coated (abrasion proof epoxy resin)

- Black, RAL 9005 **B**
- Orange, RAL 2004 **O**
- Red, RAL 3000 **R**
- Silver, RAL 9006 **S**

Axis, lag nut / screw

Setting nut and setting screw (only type A)

Steel, zinc plated, blue passivated

Contact plates

Plastic, glass fiber reinforced

- Type A: Technopolymer (Polyacetal POM)
- Type B: Technopolymer (Polyamide PA)

INFORMATION

Clamping levers with eccentric cam GN 927 are used for rapid clamping and releasing. Hereby, contrary to a clamping operation via a thread, these levers permit a torque-free clamping.

The lever has been designed to ensure that its movement cannot exceed the max. clamping force. There are no loose components since they are all assembled and mounted in their correct order.

The type A has the following advantages:

The distance between the lever cam and the clamping surface is adjustable via a fine pitch thread, allowing the clamping position to be set easily with maximum clamping force. Also, the position of the lever relative to the clamping axis can be determined.

- Constructional Features (see page)
- Clamping and Manual Forces (see page)

TECHNICAL INFORMATION

- Plastic Characteristics (see page A2)

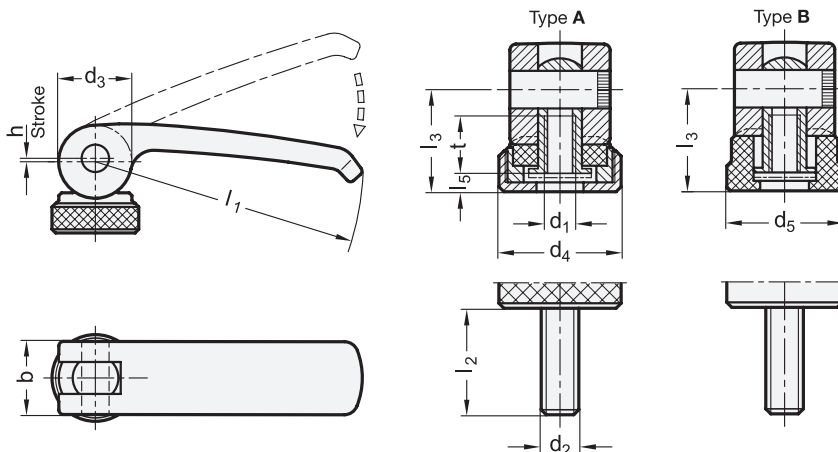

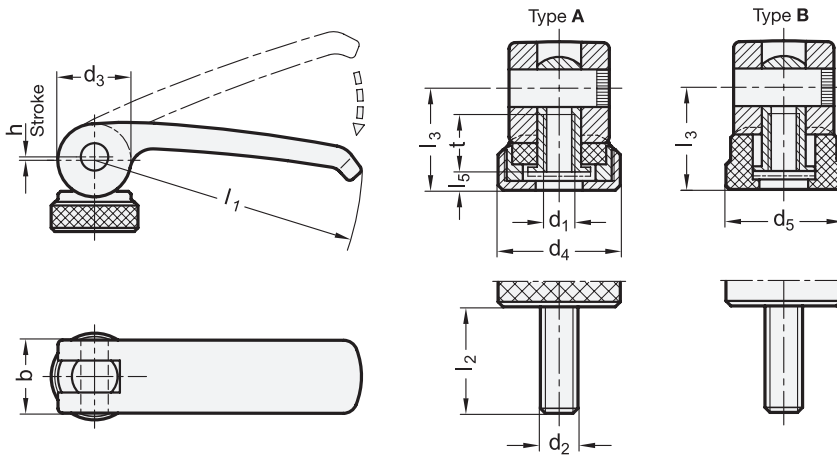

* Complete with colour index of the Clamping lever (B, O, R or S)

B	O	R	S
RAL9005	RAL2004	RAL3000	RAL9006

GN 927-with Internal Thread

Description	l1	d1	b	d3	d4	d5	h	l3	l4	l5	t	⚖
GN 927-44-M4-A-*	44	M 4	12	12	15	-	0.5	13.2	2	2.2	8	27
GN 927-44-M5-A-*	44	M 5	12	12	15	-	0.5	13.2	2	2.2	8	27
GN 927-63-M5-A-*	63	M 5	16	16	19	-	0.75	16.3	2.5	3	10	56
GN 927-63-M6-A-*	63	M 6	16	16	19	-	0.75	16.3	2.5	3	10	55
GN 927-82-M6-A-*	82	M 6	20	20	25	-	1	19.5	3	3.7	12	110
GN 927-82-M8-A-*	82	M 8	20	20	25	-	1	19.5	3	3.7	12	110
GN 927-101-M8-A-*	101	M 8	25	26	30	-	1.5	25.3	4	4.8	15	218
GN 927-101-M10-A-*	101	M 10	25	26	30	-	1.5	25.3	4	4.8	15	210
GN 927-44-M4-B-*	44	M 4	12	12	-	14	0.5	13.2	-	2.2	8	24
GN 927-44-M5-B-*	44	M 5	12	12	-	14	0.5	13.2	-	2.2	8	24
GN 927-63-M5-B-*	63	M 5	16	16	-	18.5	0.75	16.3	-	3	10	52
GN 927-63-M6-B-*	63	M 6	16	16	-	18.5	0.75	16.3	-	3	10	51
GN 927-82-M6-B-*	82	M 6	20	20	-	22.5	1	19.5	-	3.7	12	90
GN 927-82-M8-B-*	82	M 8	20	20	-	22.5	1	19.5	-	3.7	12	96
GN 927-101-M8-B-*	101	M 8	25	26	-	27	1.5	25.3	-	4.8	15	175
GN 927-101-M10-B-*	101	M 10	25	26	-	27	1.5	25.3	-	4.8	15	186

Weight type S



Clamping levers

* Complete with colour index of the Clamping lever (B, O, R or S)

 B RAL9005	 O RAL2004	 R RAL3000	 S RAL9006
---	---	---	---

GN 927-with Threaded Stud

Description	l1	d2	l2	b	d3	d4	d5	h	l3	l4	l5	Δ
GN 927-44-M4-12-A-*	44	M 4	12	12	12	15	-	0.5	13.2	2	2.2	27
GN 927-44-M4-16-A-*	44	M 4	16	12	12	15	-	0.5	13.2	2	2.2	29
GN 927-44-M4-20-A-*	44	M 4	20	12	12	15	-	0.5	13.2	2	2.2	29
GN 927-44-M4-25-A-*	44	M 4	25	12	12	15	-	0.5	13.2	2	2.2	29
GN 927-44-M4-30-A-*	44	M 4	30	12	12	15	-	0.5	13.2	2	2.2	30
GN 927-44-M5-12-A-*	44	M 5	12	12	12	15	-	0.5	13.2	2	2.2	29
GN 927-44-M5-16-A-*	44	M 5	16	12	12	15	-	0.5	13.2	2	2.2	29
GN 927-44-M5-20-A-*	44	M 5	20	12	12	15	-	0.5	13.2	2	2.2	30
GN 927-44-M5-25-A-*	44	M 5	25	12	12	15	-	0.5	13.2	2	2.2	30
GN 927-44-M5-30-A-*	44	M 5	30	12	12	15	-	0.5	13.2	2	2.2	31
GN 927-44-M5-35-A-*	44	M 5	35	12	12	15	-	0.5	13.2	2	2.2	32
GN 927-44-M5-40-A-*	44	M 5	40	12	12	15	-	0.5	13.2	2	2.2	32
GN 927-63-M5-16-A-*	63	M 5	16	16	16	19	-	0.75	16.3	2.5	3	60
GN 927-63-M5-20-A-*	63	M 5	20	16	16	19	-	0.75	16.3	2.5	3	60
GN 927-63-M5-25-A-*	63	M 5	25	16	16	19	-	0.75	16.3	2.5	3	62
GN 927-63-M5-30-A-*	63	M 5	30	16	16	19	-	0.75	16.3	2.5	3	60
GN 927-63-M5-35-A-*	63	M 5	35	16	16	19	-	0.75	16.3	2.5	3	63
GN 927-63-M5-40-A-*	63	M 5	40	16	16	19	-	0.75	16.3	2.5	3	63
GN 927-63-M5-50-A-*	63	M 5	50	16	16	19	-	0.75	16.3	2.5	3	64
GN 927-63-M6-16-A-*	63	M 6	16	16	16	19	-	0.75	16.3	2.5	3	58
GN 927-63-M6-20-A-*	63	M 6	20	16	16	19	-	0.75	16.3	2.5	3	60
GN 927-63-M6-25-A-*	63	M 6	25	16	16	19	-	0.75	16.3	2.5	3	63
GN 927-63-M6-30-A-*	63	M 6	30	16	16	19	-	0.75	16.3	2.5	3	64
GN 927-63-M6-35-A-*	63	M 6	35	16	16	19	-	0.75	16.3	2.5	3	65
GN 927-63-M6-40-A-*	63	M 6	40	16	16	19	-	0.75	16.3	2.5	3	66
GN 927-63-M6-50-A-*	63	M 6	50	16	16	19	-	0.75	16.3	2.5	3	68
GN 927-82-M6-20-A-*	82	M 6	20	20	20	25	-	1	19.5	3	3.7	118
GN 927-82-M6-25-A-*	82	M 6	25	20	20	25	-	1	19.5	3	3.7	118
GN 927-82-M6-30-A-*	82	M 6	30	20	20	25	-	1	19.5	3	3.7	120
GN 927-82-M6-35-A-*	82	M 6	35	20	20	25	-	1	19.5	3	3.7	120
GN 927-82-M6-40-A-*	82	M 6	40	20	20	25	-	1	19.5	3	3.7	120
GN 927-82-M6-50-A-*	82	M 6	50	20	20	25	-	1	19.5	3	3.7	122
GN 927-82-M6-60-A-*	82	M 6	60	20	20	25	-	1	19.5	3	3.7	120
GN 927-82-M8-20-A-*	82	M 8	20	20	20	25	-	1	19.5	3	3.7	110
GN 927-82-M8-25-A-*	82	M 8	25	20	20	25	-	1	19.5	3	3.7	122
GN 927-82-M8-30-A-*	82	M 8	30	20	20	25	-	1	19.5	3	3.7	120
GN 927-82-M8-35-A-*	82	M 8	35	20	20	25	-	1	19.5	3	3.7	125
GN 927-82-M8-40-A-*	82	M 8	40	20	20	25	-	1	19.5	3	3.7	125
GN 927-82-M8-50-A-*	82	M 8	50	20	20	25	-	1	19.5	3	3.7	130
GN 927-82-M8-60-A-*	82	M 8	60	20	20	25	-	1	19.5	3	3.7	135
GN 927-101-M8-20-A-*	101	M 8	20	25	26	30	-	1.5	25.3	4	4.8	220
GN 927-101-M8-25-A-*	101	M 8	25	25	26	30	-	1.5	25.3	4	4.8	227
GN 927-101-M8-30-A-*	101	M 8	30	25	26	30	-	1.5	25.3	4	4.8	227
GN 927-101-M8-35-A-*	101	M 8	35	25	26	30	-	1.5	25.3	4	4.8	228
GN 927-101-M8-40-A-*	101	M 8	40	25	26	30	-	1.5	25.3	4	4.8	232
GN 927-101-M8-50-A-*	101	M 8	50	25	26	30	-	1.5	25.3	4	4.8	233
GN 927-101-M8-60-A-*	101	M 8	60	25	26	30	-	1.5	25.3	4	4.8	237
GN 927-101-M10-20-A-*	101	M 10	20	25	26	30	-	1.5	25.3	4	4.8	230
GN 927-101-M10-25-A-*	101	M 10	25	25	26	30	-	1.5	25.3	4	4.8	231
GN 927-101-M10-30-A-*	101	M 10	30	25	26	30	-	1.5	25.3	4	4.8	230
GN 927-101-M10-35-A-*	101	M 10	35	25	26	30	-	1.5	25.3	4	4.8	237
GN 927-101-M10-40-A-*	101	M 10	40	25	26	30	-	1.5	25.3	4	4.8	238
GN 927-101-M10-50-A-*	101	M 10	50	25	26	30	-	1.5	25.3	4	4.8	245
GN 927-101-M10-60-A-*	101	M 10	60	25	26	30	-	1.5	25.3	4	4.8	240



Clamping levers 3

GN 927-with Threaded Stud

Description	l1	d2	l2	b	d3	d4	d5	h	l3	l4	l5	⚖️
GN 927-44-M4-12-B-*	44	M 4	12	12	12	-	14	0.5	13.2	-	2.2	24
GN 927-44-M4-16-B-*	44	M 4	16	12	12	-	14	0.5	13.2	-	2.2	26
GN 927-44-M4-20-B-*	44	M 4	20	12	12	-	14	0.5	13.2	-	2.2	26
GN 927-44-M4-25-B-*	44	M 4	25	12	12	-	14	0.5	13.2	-	2.2	26
GN 927-44-M4-30-B-*	44	M 4	30	12	12	-	14	0.5	13.2	-	2.2	27
GN 927-44-M5-12-B-*	44	M 5	12	12	12	-	14	0.5	13.2	-	2.2	26
GN 927-44-M5-16-B-*	44	M 5	16	12	12	-	14	0.5	13.2	-	2.2	26
GN 927-44-M5-20-B-*	44	M 5	20	12	12	-	14	0.5	13.2	-	2.2	27
GN 927-44-M5-25-B-*	44	M 5	25	12	12	-	14	0.5	13.2	-	2.2	27
GN 927-44-M5-30-B-*	44	M 5	30	12	12	-	14	0.5	13.2	-	2.2	28
GN 927-44-M5-35-B-*	44	M 5	35	12	12	-	14	0.5	13.2	-	2.2	29
GN 927-44-M5-40-B-*	44	M 5	40	12	12	-	14	0.5	13.2	-	2.2	29
GN 927-63-M5-16-B-*	63	M 5	16	16	16	-	18.5	0.75	16.3	-	3	56
GN 927-63-M5-20-B-*	63	M 5	20	16	16	-	18.5	0.75	16.3	-	3	55
GN 927-63-M5-25-B-*	63	M 5	25	16	16	-	18.5	0.75	16.3	-	3	56
GN 927-63-M5-30-B-*	63	M 5	30	16	16	-	18.5	0.75	16.3	-	3	56
GN 927-63-M5-35-B-*	63	M 5	35	16	16	-	18.5	0.75	16.3	-	3	56
GN 927-63-M5-40-B-*	63	M 5	40	16	16	-	18.5	0.75	16.3	-	3	56
GN 927-63-M5-50-B-*	63	M 5	50	16	16	-	18.5	0.75	16.3	-	3	56
GN 927-63-M6-16-B-*	63	M 6	16	16	16	-	18.5	0.75	16.3	-	3	56
GN 927-63-M6-20-B-*	63	M 6	20	16	16	-	18.5	0.75	16.3	-	3	56
GN 927-63-M6-25-B-*	63	M 6	25	16	16	-	18.5	0.75	16.3	-	3	56
GN 927-63-M6-30-B-*	63	M 6	30	16	16	-	18.5	0.75	16.3	-	3	60
GN 927-63-M6-35-B-*	63	M 6	35	16	16	-	18.5	0.75	16.3	-	3	60
GN 927-63-M6-40-B-*	63	M 6	40	16	16	-	18.5	0.75	16.3	-	3	59
GN 927-63-M6-50-B-*	63	M 6	50	16	16	-	18.5	0.75	16.3	-	3	60
GN 927-82-M6-20-B-*	82	M 6	20	20	20	-	22.5	1	19.5	-	3.7	122
GN 927-82-M6-25-B-*	82	M 6	25	20	20	-	22.5	1	19.5	-	3.7	12
GN 927-82-M6-30-B-*	82	M 6	30	20	20	-	22.5	1	19.5	-	3.7	122
GN 927-82-M6-35-B-*	82	M 6	35	20	20	-	22.5	1	19.5	-	3.7	122
GN 927-82-M6-40-B-*	82	M 6	40	20	20	-	22.5	1	19.5	-	3.7	122
GN 927-82-M6-50-B-*	82	M 6	50	20	20	-	22.5	1	19.5	-	3.7	122
GN 927-82-M6-60-B-*	82	M 6	60	20	20	-	22.5	1	19.5	-	3.7	122
GN 927-82-M8-20-B-*	82	M 8	20	20	20	-	22.5	1	19.5	-	3.7	122
GN 927-82-M8-25-B-*	82	M 8	25	20	20	-	22.5	1	19.5	-	3.7	100
GN 927-82-M8-30-B-*	82	M 8	30	20	20	-	22.5	1	19.5	-	3.7	107
GN 927-82-M8-35-B-*	82	M 8	35	20	20	-	22.5	1	19.5	-	3.7	108
GN 927-82-M8-40-B-*	82	M 8	40	20	20	-	22.5	1	19.5	-	3.7	110
GN 927-82-M8-50-B-*	82	M 8	50	20	20	-	22.5	1	19.5	-	3.7	120
GN 927-82-M8-60-B-*	82	M 8	60	20	20	-	22.5	1	19.5	-	3.7	120
GN 927-101-M8-20-B-*	101	M 8	20	25	26	-	27	1.5	25.3	-	4.8	200
GN 927-101-M8-25-B-*	101	M 8	25	25	26	-	27	1.5	25.3	-	4.8	202
GN 927-101-M8-30-B-*	101	M 8	30	25	26	-	27	1.5	25.3	-	4.8	204
GN 927-101-M8-35-B-*	101	M 8	35	25	26	-	27	1.5	25.3	-	4.8	204
GN 927-101-M8-40-B-*	101	M 8	40	25	26	-	27	1.5	25.3	-	4.8	208
GN 927-101-M8-50-B-*	101	M 8	50	25	26	-	27	1.5	25.3	-	4.8	210
GN 927-101-M8-60-B-*	101	M 8	60	25	26	-	27	1.5	25.3	-	4.8	213
GN 927-101-M10-20-B-*	101	M 10	20	25	26	-	27	1.5	25.3	-	4.8	205
GN 927-101-M10-25-B-*	101	M 10	25	25	26	-	27	1.5	25.3	-	4.8	207
GN 927-101-M10-30-B-*	101	M 10	30	25	26	-	27	1.5	25.3	-	4.8	209
GN 927-101-M10-35-B-*	101	M 10	35	25	26	-	27	1.5	25.3	-	4.8	212
GN 927-101-M10-40-B-*	101	M 10	40	25	26	-	27	1.5	25.3	-	4.8	215
GN 927-101-M10-50-B-*	101	M 10	50	25	26	-	27	1.5	25.3	-	4.8	210
GN 927-101-M10-60-B-*	101	M 10	60	25	26	-	27	1.5	25.3	-	4.8	224

Weight type S



3
Clamping levers